

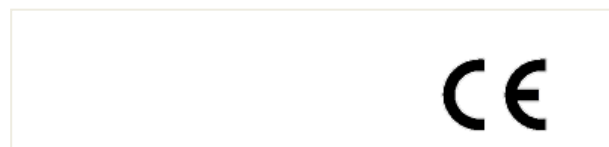

**GASOLINE TILLER
RAC139PTIL-A/
RAC139PTIL6C-B
ORIGINAL INSTRUCTION MANUAL**











BUILDER SAS
32, rue Aristide Bergès - ZI 31270 Cugnaux - France
MADE IN PRC



WARNING: Read and understand all instructions before use.

WARNING SYMBOLS

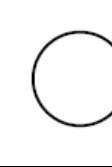
The following symbols are used in this manual and/or on the machine:

	<p>Warning, read the instruction manual before use the machine.</p>
	<p>Risk of injury due to flying parts! Keep bystanders away!</p>
	<p>Risk of injury caused by rotating machine parts.</p>
	<p>Guaranteed sound power level.</p>
	<p>Choke, cold engine start</p>
	<p>Engine speed is fast</p>
	<p>Engine speed is slow.</p>
	<p>Engine is going to be off</p>
	<p>Unleaded gasoline</p>
	<p>Engine delivered without adding oil. Please ensure to adding engine oil before use. Inspect engine oil level before each time use.</p>

Instruction handbook

Comprehensive instructions and information on all aspects of maintenance and safe use of the machine shall be provided in the instruction handbook. It shall comply with 5.5 of EN 292-2:1991. In particular, the following points shall be emphasised;

- a) That the machine shall always be used in accordance with the manufacturer's instructions laid down in the instruction handbook;
- b) The engine shall be stopped when carrying out maintenance and cleaning operations, when changing tools and when being transported by means other than under its own power;
- c) Information on the hazards when working on slopes and the precautions to take;
- d) Information on the special hazards when working on difficult soil (stony, hard, etc.);
- e) That the adjustable part of the protective device shall be adjusted to the working depth of the tool so that only that part of the working tool that cuts into the soil remains uncovered. This does not apply to motor hoes;
- f) The sound pressure and power levels measured according to prEN 1553:1996;
- g) The level of vibrations on handlebar grips measured according to EN 1033:1995;
- h) Recommendations for starting up under normal conditions and, if necessary, for the auxiliary or secondary starting device;
- i) That the machine should only be operated by suitably trained persons;
- j) That during the operation of the machine safety shoes should be worn;
- k) Information regarding the holding points which allow the machine to be handled.

An example of complete safety instructions follows:

The following good practices should be stated as appropriate;

1) Training

- a) Read the instructions carefully. Be familiar with the controls and the proper use of the equipment;
- b) Never allow children or people unfamiliar with these instructions to use the machine. Local regulations can restrict the age of the operator;
- c) Never work while people, especially children, or pets are nearby;
- d) Keep in mind that the operator or user is responsible for accidents or hazards occurring to other people or their property.

2) Preparation

- a) While working, always wear substantial footwear and long trousers. Do not operate the equipment when barefoot or wearing open sandals;

- b) Thoroughly inspect the area where the equipment is to be used and remove all objects which can be thrown up by the machine;
- c) **WARNING** – Petrol is highly flammable;
 - Store fuel in containers specifically designed for this purpose;
 - Refuel outdoors only and don not smoke while refueling;
 - Add fuel before starting the engine. Never remove the cap of the fuel tank or add petrol while the engine running or when the engine is hot;
 - If petrol is spilled, do not attempt to start the engine but move the machine away from the area of spillage and avoid creating any source of ignition until petrol vapours have dissipated;
 - Replace all fuel tank an container caps securely;
- d) Replace faulty silencers;
- e) Before using, always visually inspect to see that the tools are not worn out or damaged. Replace worn out or damaged elements and bolts in sets to preserve balance.

3) Operation

- a) Do not operate the engine in a confined space where dangerous carbon monoxide fumes can collect;
- b) Work only in daylight or in good artificial light;
- c) Always be sure of your footing on slopes;
- d) Walk, never run with the machine;
- e) For wheeled rotary machines, work across the slopes, never up and down;
- f) Exercise extreme caution when changing direction on slopes;
- g) Do not work on excessively steep slopes;
- h) Use extreme caution when reversing or pulling the machine towards you;
- i) Do not change the engine governor setting or overspeed the engine;
- j) Start the engine carefully according to manufacturer instructions and with feet well away from the tool(s);
- k) Do not put your hands or feet near or under rotating parts;
- l) Never pick up or carry a machine while the engine is running;
- m) Stop the engine:
 - Whenever you leave the machine;
 - Before refueling;
- n) Reduce the throttle setting during engine shut down and, if the engine is provided with a shut-off valve, turn the fuel off at the conclusion or working;

4) Maintenance and storage

- a) Keep all nuts, bolts and screws tight to ensure the equipment is in safe working condition;
- b) Never store the equipment with petrol in the tank inside a building where fumes can reach an open flame or spark;
- c) Allow the engine to cool before storing in any enclosure;
- d) To reduce the fire hazard, keep the engine, silencer, battery compartment and petrol storage area free of vegetative material and excessive grease;
- e) Replace worn or damaged parts for safety;
- f) If the fuel tank has to be drained, this shall be done outdoors.

Technical Data:

Tiller Model:	RAC139PTIL-A	RAC139PTIL6C-B
Engine Model:	DB475	DB475
Type-approval No:	e13*2016/1628*2016/1628SYA1/P*0437*00	e13*2016/1628*2016/1628SYA1/P*0437*00
Rated Power:	2.5 kW	2.5 kW
Rated Speed:	3000/min	3000/min
Displacement:	139cm ³	139cm ³
Starting:	Recoil	Recoil
Oil Capacity:	0.50L, SAE 15W-40	0.50L, SAE 15W-40
Tank Volume:	1.20L	1.20L
Blade Diameter:	260mm	260mm
Cutting Path:	360mm /	590mm
Sound power level guaranteed LwA:	93dB(A)	93dB(A)
Sound pressin level Lpa	75dB(A), K=3dB(A)	75dB(A), , K=3dB(A)
Sound power level measured LwA:	90dB(A), K=3dB(A)	89.78dB(A), K=3dB(A)
Vibration:	Left handle: 1.721m/s ² Right handle: 1.592m/s ² K=1.5m/s ²	Left handle: 1.721m/s ² Right handle: 1.592m/s ² K=1.5m/s ²
Weight	33kg	35kg

Content

- 1/ DESCRIPTION
- 2/ ASSEMBLY OF HANDLE
- 3/ BLADE ASSEMBLY
- 4/ GENERAL SAFETY INSTRUCTIONS
- 5/ OPERATION
- 6/ TRANSPORTATION AND STORAGE
- 7/ TROUBLES-CAUSES-TROUBLESHOOTING
- 8/ INSPECTIONS AND MAINTENANCE
- 9/ EXPLODED DIAGRAM
- 10/ CE DECLARATION OF CONFORMITY
- 11/ WARRANTY
- 12/ PRODUCT FAILURE
- 13/ WARRANTY EXCLUSIONS

1-DESCRIPTION



- 1, Clutch Handle
- 2, Left Handle
- 3, Gasoline Engine
- 4, Right Handle
- 5, Blade
- 6, Aluminum Gearbox

2-ASSEMBLY OF HANDLE

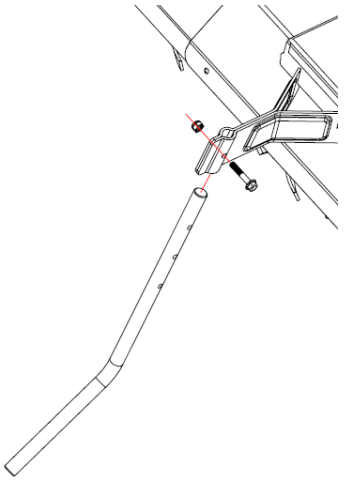
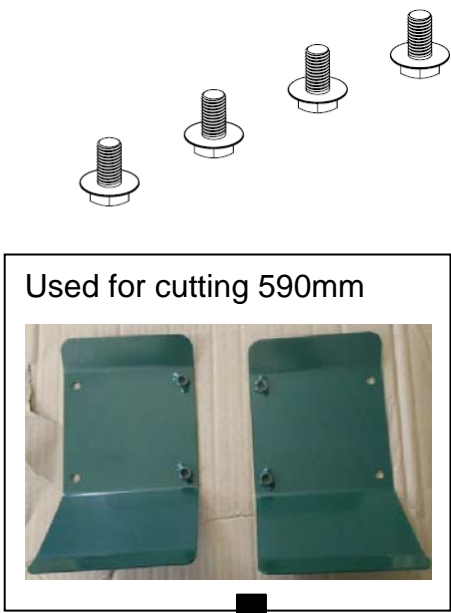
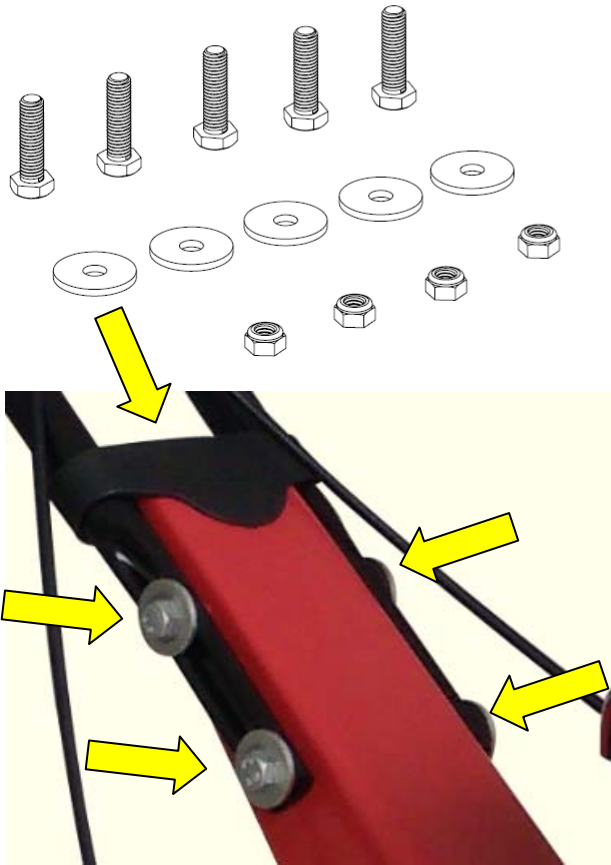

3-BLADE ASSEMBLY



Cutting width 360mm

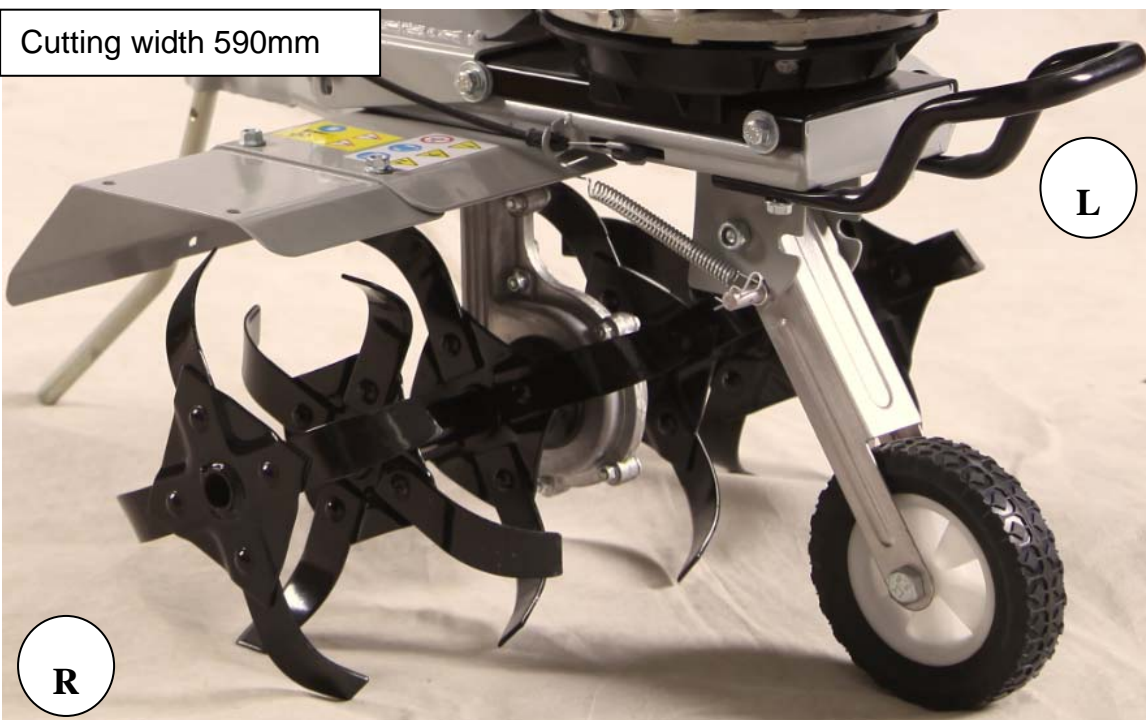

Cutting width 590mm

L

R

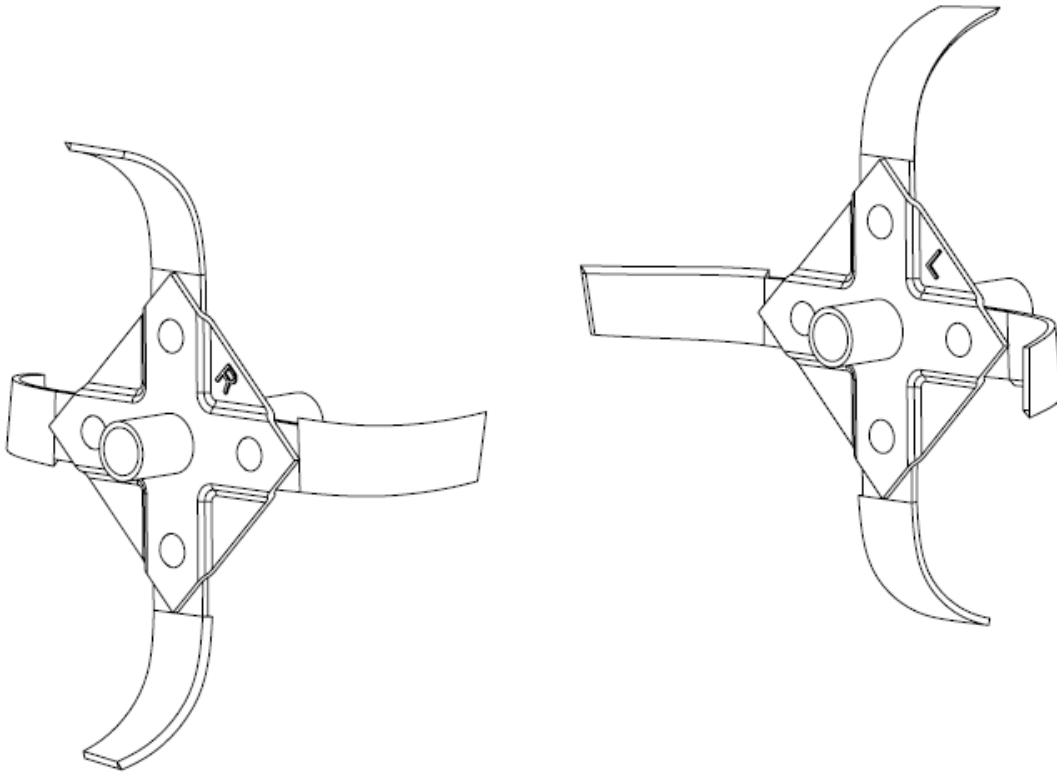

Note: L means left blade, which is different from right blade(R). L and R are engraved on the blade.

4-GENERAL SAFETY INSTRUCTIONS

- * Do not use the machine until you have read the instruction manual carefully.
- * Observe any safety instruction included in the manual.
- * Be responsible to the others
- * The unit is provided a foot-operated brake than stops the blades within 3 seconds after the drive lever tripping. Never attempt stopping the unit or tilting the unit with blades still rotating. Wait for the blades to come stand by themselves.
- * If the blades get in touch with foreign objects, stop the engine immediately and check the unit with blades stopped for damage. Continue working with unit undamaged only.
- * Walk while working and do not run.
- * Always walk forward only. Never pull the unit walking backwards.
- * When working on a slope, always work across, never down and up. Be particularly careful when changing direction.
- * When travelling across no-grass areas and transferring the unit from the work area to another one, the blades must not be operating.

5-OPERATION

Engine Oil

Engine Oil

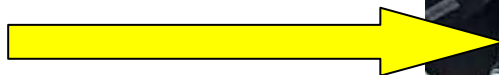

Warning: Engine delivered without oil, please add 0.50 liter of oil before use. Oil should be changed for the first time after 2 hours, then replace engine oil every 30 hours. Inspect oil level before each time use. The oil level must always be between the MAX and the MIN sign on dipstick.

Engine Oil Type: SAE 15W-40, API SE or SF, for general use.



Gasoline Tank Capacity: 1200ml

Gasoline Type: Fresh and unleaded gasoline

Warning! Never fill gasoline into fuel tank while the machine is in an enclosed area;

Warning! Do not fill gasoline into fuel tank while the engine is running or still hot;

Warning! Never smoke while you fill up gasoline into the fuel tank;

Warning! Do not use your mobile phone while you fill up gasoline into the fuel tank;

Warning! Do not mix oil into the gasoline

Guiding wheel in work position

Put the wheel in pos.B for tilling.

CAUTION!

Transport the unit with the wheel in position A.

The wheel should be adjusted with engine off only!

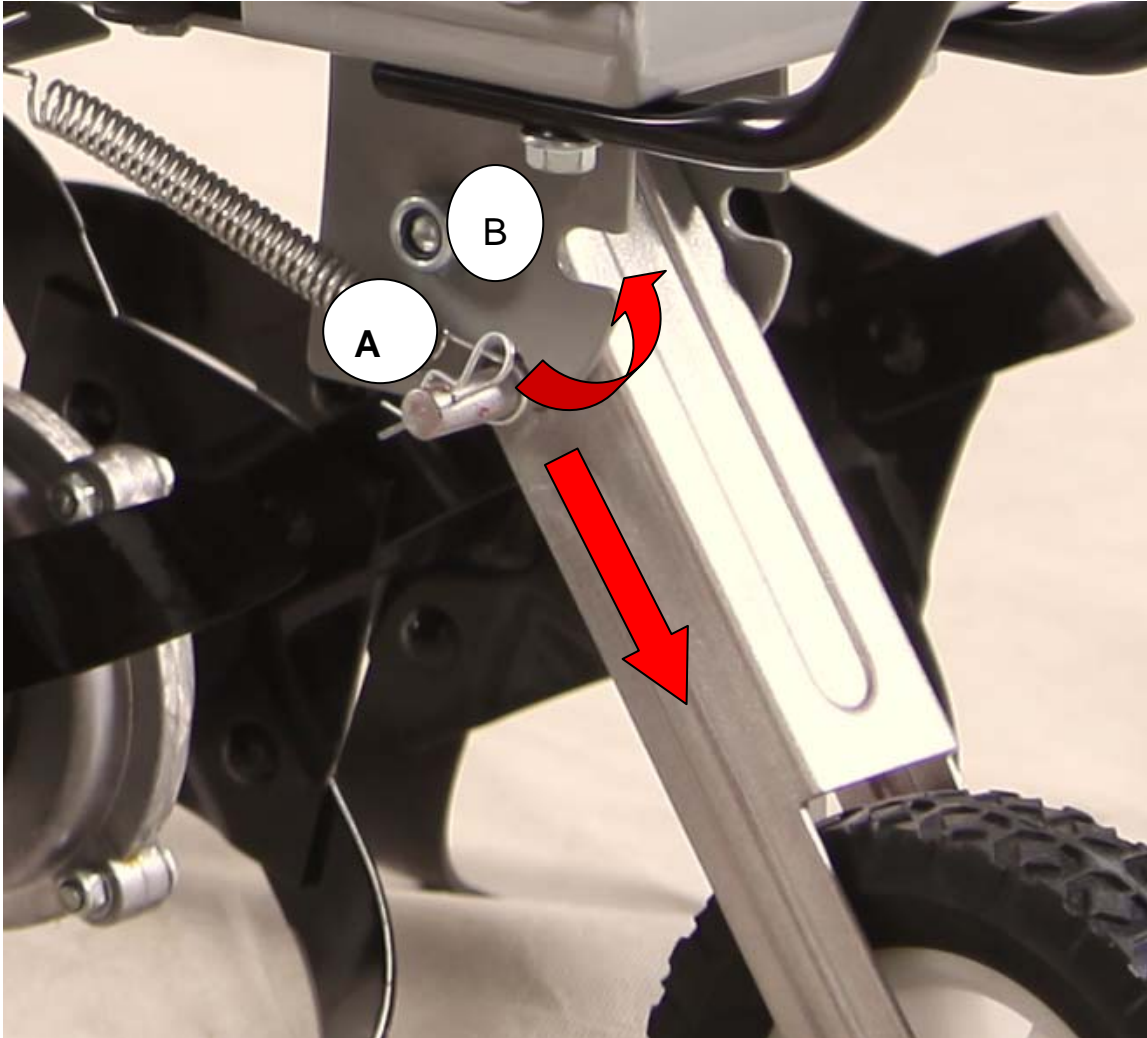

Cold Engine Start

Put the lever on the choke position. Pull the starter cable evenly. The engine should start up after 3-5 pulls. Put the lever at the required speed, FAST or SLOW and pull the clutch handle in 2 steps against the handle.

Notice: If the engine is heated up, it is possible to start up in the slow/fast position. When the clutch handle returns normal position, the drive will be off but the engine works on.

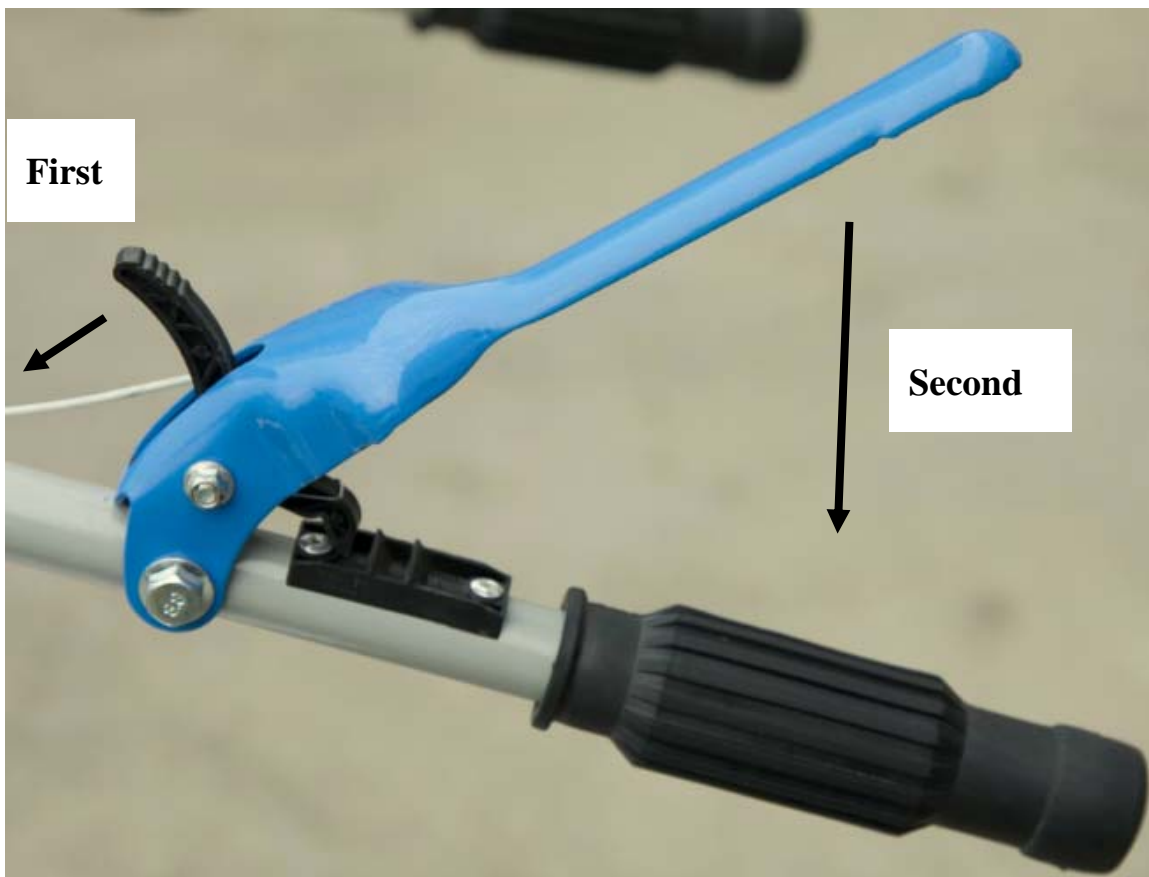

6- TRANSPORTATION AND STORAGE

- The unit is allowed to be transported with the engine off only
- Clean the unit thoroughly before putting in on storage
- Store the unit at a dry clean place



Fuel or oil may leak at transport. Secure the unit as appropriate and take preventive action to protect the environment against contamination.

7- TROUBLES-CAUSES-TROUBLESHOOTING

Trouble	Cause	Troubleshooting
Engine will not start	<ol style="list-style-type: none"> 1. Empty tank 2. Fouled air filter 3. No ignition spark 4. Flooded engine 	<ol style="list-style-type: none"> 1. Fill in the tank, check the fuel in carburetor, and clean the hole in the lid with a needle. 2. Clean the air filter. 3. Clean the ignition plug or use a new one. 4. Remove the plug, clean and wipe dry; pull the starting cable several times with the plug removed.
Faltering engine	<ol style="list-style-type: none"> 1. Ignition cable detached 2. Fuel piping clogged or wrong fuel 3. Blocked hole in the fuel tank cover. 4. Water or dirt in fuel system 5. Fouled air filter 	<ol style="list-style-type: none"> 1. Push the plug socket firmly on the plug. 2. Clean fuel piping, use fresh/different fuel. 3. Replace the fuel tank cover 4. Drain the fuel and refuel. 5. Clean the air filter
Engine often switches off when idling	<ol style="list-style-type: none"> 1. Too long ignition interval, defective ignition plug 2. Carburetor not set correctly 3. Fouled air filter 	<ol style="list-style-type: none"> 1. Adjust/replace the ignition plug 2. Set up the carburetor
Drive will not work properly	<ol style="list-style-type: none"> 1. Check the drive lever cable tension 2. Drive does not work 	<ol style="list-style-type: none"> 1. Adjust the cable tension if necessary. 2. Have the unit checked in a servicing shop
Excessive vibrations	<ol style="list-style-type: none"> 1. Loose lock screws 	<ol style="list-style-type: none"> 1. Tighten the lock screws

8- INSPECTION AND MAINTENANCE

8.1 Inspections and Maintenance Safety Instructions

The machine will serve as a sufficient aid only if maintained and care for appropriately. Insufficient maintenance and care may result in accidents and injuries.

- Prior to any works on the unit, always switch the engine off and pull the spark plug socket out!
- Never use aggressive detergents for cleaning. That could result in damage or destruction of the unit.

8.2 Inspection and Maintenance Schedule

Time Interval	Description
Before start of work	<ul style="list-style-type: none">● Check the engine oil level● Check for any loosen parts
Every 25 operating hours	<ul style="list-style-type: none">● Exchange the engine oil● Check the engine oil level● Clean the air filter● Remove remnants of grass from rotating parting with a brush or a blunt tool● Wipe the body with a soft cloth● When the dirt is hardened, the unit may be cleaned with soft cloth wetted in soapy waters
Every 100 operating hours	<ul style="list-style-type: none">● Check, clean or replace the ignition sparkle plug

9- EXPLODED DIAGRAM

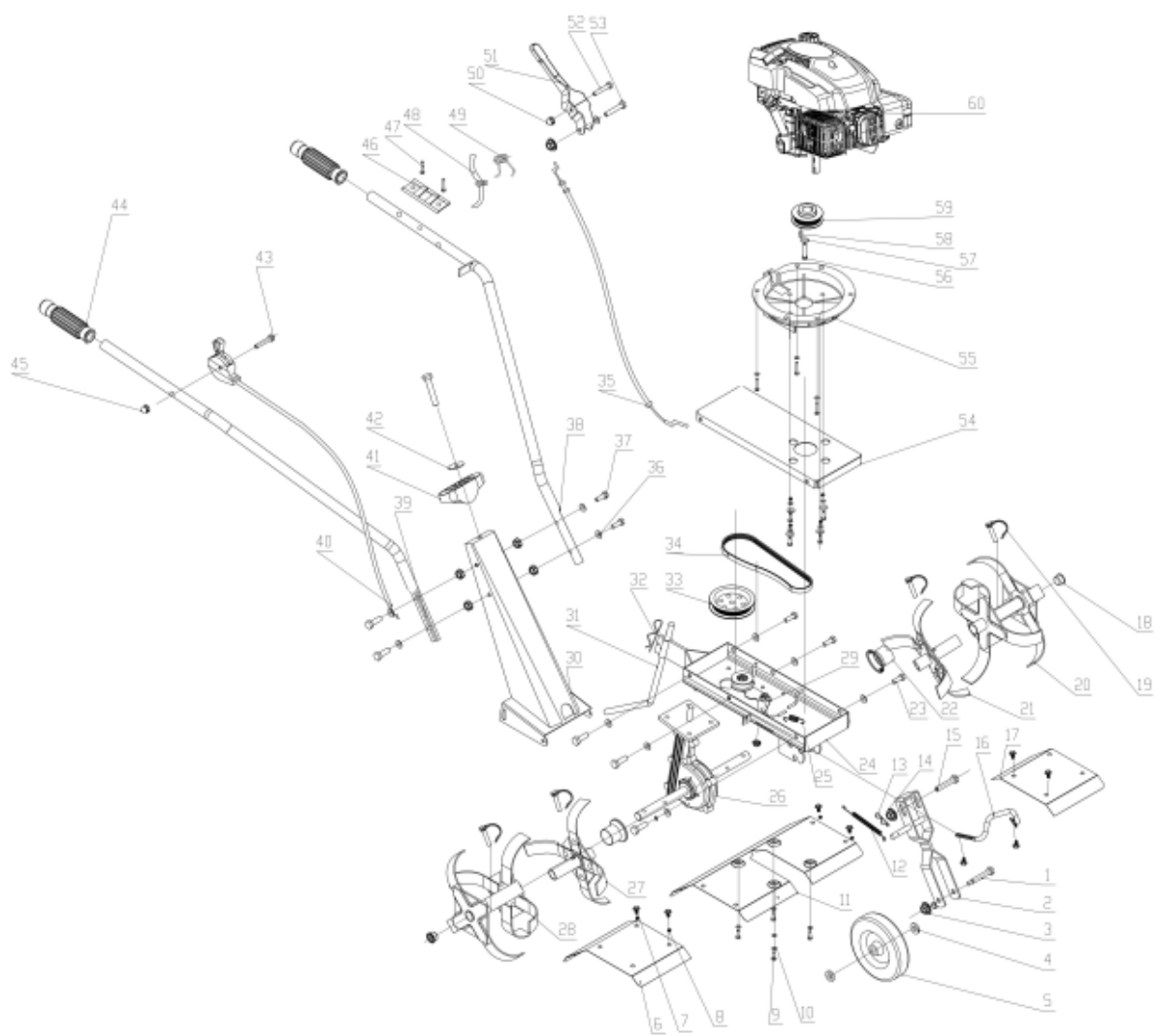

10- CE DECLARATION OF CONFORMITY



Declaration of conformity

BUILDER

ZI - 32, rue Aristide Bergès - 31270 Cugnaux - France

Tel: +33 (0)5.34.502.502 Fax: +33 (0)5.34.502.503

Declares that the machinery designated below:

GASOLINE TILLER

Model: RAC139PTIL-A

Serial number: 20210171966-20210172215

The people name holding the technical file: Mr. Olivier Patriarca

Complies with the provisions of the Directive & quot; machinery & quot; 2006/42 / EC and national laws transposing it;

Also complies with the following European directives:

The EMC Directive 2014/30 / EU

Emission directive (EU) 2016/1628

The Directive on Noise Emission 2000/14 / EC + 2005/88 / EC

Noise measurements 90 dB(A) and the guaranteed noise 93 dB(A)

Notify Body for Noise Certificate: TÜV Rheinland Luxemburg GmbH

Also complies with European standards, with national standards and the following technical provisions:

EN 709: 1997+A4

EN ISO 14982:2009

Toulouse, France

Le: 01-01-2021

Philippe MARIE / PDG

11. WARRANTY



WARRANTY

The manufacturer guarantees the product against defects in material and workmanship for a period of 2 years from the date of the original purchase. The warranty only applies if the product is for household use. The warranty does not cover breakdowns due to normal wear and tear.

The manufacturer agrees to replace parts identified as defective by the designated distributor. The manufacturer does not accept responsibility for the replacement of the machine, in whole or in part, and/or ensuing damage.

The warranty does not cover breakdowns due to:

- insufficient maintenance.
- abnormal assembly, adjustment or operations of the product.
- parts subject to normal wear and tear.

The warranty does not extend to:

- shipping and packaging costs.
- using the tool for a purpose other than that for which it was designed.
- the use and maintenance of the machine done in a manner not described in the user manual.

Due to our policy of continuous product improvement, we reserve the right to alter or change specifications without notice. Consequently, the product may be different from the information contained therein, but a modification will be undertaken without notice if it is recognized as an improvement of the preceding characteristic.

READ THE MANUAL CAREFULLY BEFORE USING THE MACHINE.

When ordering spare parts, please indicate the part number or code, you can find this in the spare parts list in this manual. Keep the purchase receipt; without it, the warranty is invalid. To help you with your product, we invite you to contact us by phone or via our website:

- **+33 (0)9.70.75.30.30**
- **<https://services.swap-europe.com/contact>**

You must create a "ticket" via the web platform.

- Register or create your account.
- Indicate the reference of the tool.
- Choose the subject of your request.
- Describe your problem.
- Attach these files: invoice or sales receipt, photo of the identification plate (serial number), photo of the part you need (for example: pins on the transformer plug which are broken).



12. PRODUCT FAILURE

WHAT TO DO IF MY MACHINE BREAKS DOWN?

If you bought your product in a store:

- a) Empty the fuel tank.
- b) Make sure that your machine is complete with all accessories supplied, and clean! If this is not the case, the repairer will refuse the machine.

Go to the store with the complete machine and with the receipt or invoice.

If you bought your product on a website:

- a) Empty the fuel tank.
- b) Make sure that your machine is complete with all accessories supplied, and clean! If this is not the case, the repairer will refuse the machine.
- c) Create a SWAP-Europe service ticket on the site: <https://services.swap-europe.com> When making the request on SWAP-Europe, you must attach the invoice and the photo of the nameplate (serial number).
- d) Contact the repair station to make sure it is available before dropping off the machine.

Go to the repair station with the complete machine packed, accompanied by the purchase invoice and the station support sheet downloadable after the service request is completed on the SWAP-Europe site

For machines with engine failure from manufacturers BRIGGS & STRATTON, HONDA and RATO, please refer to the following instructions.

Repairs will be done by approved engine manufacturers of these manufacturers, see their site:

- <http://www.briggsandstratton.com/eu/fr>
- <http://www.honda-engines-eu.com/fr/service-network-page;jsessionid=5EE8456CF39CD572AA2AEEDFD290CDAE>
- <https://www.rato-europe.com/it/service-network>

Please keep your original packaging to allow for after-sales service returns or pack your machine with a similar cardboard box of the same dimensions.

For any question concerning our after-sales service you can make a request on our website <https://services.swap-europe.com>

Our hotline remains available at +33 (9) 70 75 30 30.



13. WARRANTY EXCLUSIONS

THE WARRANTY DOES NOT COVER:

- Start-up and setting up of the product.
- Damage resulting from normal wear and tear of the product.
- Damage resulting from improper use of the product.
- Damage resulting from assembly or start-up not in accordance with the user manual.
- Breakdowns related to carburetion beyond 90 days and fouling of carburetors.
- Periodic and standard maintenance events.
- Actions of modification and dismantling that directly void the warranty.
- Products whose original authentication marking (brand, serial number) has been degraded, altered or withdrawn.
- Replacement of consumables.
- The use of non-original parts.
- Breakage of parts following impacts or projections.
- Accessories breakdowns.
- Defects and their consequences linked to any external cause.
- Loss of components and loss due to insufficient screwing.
- Cutting components and any damage related to the loosening of parts.
- Overload or overheating.
- Poor power supply quality: faulty voltage, voltage error, etc.
- Damages resulting from the deprivation of enjoyment of the product during the time necessary for repairs and more generally the costs related to the immobilization of the product.
- The costs of a second opinion established by a third party following an estimate by a SWAP-Europe repair station
- The use of a product which would show a defect or a breakage which was not the subject of an immediate report and/or repair with the services of SWAP-Europe.
- Deterioration linked to transport and storage*.
- Launchers beyond 90 days.
- Oil, petrol, grease.
- Damages related to the use of non-compliant fuels or lubricants.

* In accordance with transport legislation, damage related to transport must be declared to carriers within 48 hours maximum after observation by registered letter with acknowledgement of receipt.

This document is a supplement to your notice, a non-exhaustive list.

Attention: all orders must be checked in the presence of the delivery person. In case of refusal by the delivery person, it you must simply refuse the delivery and notify your refusal.

Reminder: the reserves do not exclude the notification by registered letter with acknowledgement within 72 hours.

Information:

Thermal devices must be wintered each season (service available on the SWAP-Europe site). Batteries must be charged before being stored.